

HLA Typing in a Family Prone to Malignant Hyperthermia

IRVING LUTSKY, V.M.D.,* JOYCE WITKOWSKI, B.S.,† ERNEST O. HENSCHL, M.D.‡

Malignant hyperthermia (MH), a world-wide pharmacogenetic syndrome, is a major cause of anesthetic-induced mortality in North America.¹ The biochemical basis of MH probably reflects an increased sensitivity of the sarcoplasmic reticulum to anesthetic agents and muscle relaxants (*e.g.*, diethyl ether, halothane and succinylcholine).

Genetic predisposition to MH has been thought to be associated with an autosomal dominant trait. Recently Ellis suggested that while the overall pattern is one of dominant inheritance, MH may be inherited as a polygenic condition.² In any inherited condition with potentially lethal consequences, recognition of a patient's familial predisposition prior to the triggering of an MH episode is of paramount importance. Unfortunately, an infallible predictive test for MH does not exist.

For a number of years a relatively large number of MH episodes have occurred in Wausau, Wisconsin, apparently reflecting the genetic background of this area's residents.³ The proximity and cooperation of these individuals potentially susceptible to MH, and the continuing increase in the number of diseases in which susceptibility appears associated with the major histocompatibility system⁴ encouraged us to investigate the possibility of an association between the human leukocyte antigen (HLA) system and susceptibility to MH.

METHODS

We studied 31 members of a MH prone family, including 10 known MH reactors and 21 individuals whose susceptibility to MH was not definitely known; four members of this family group were known to have succumbed following episodes of MH (fig. 1). The four

deaths followed administration of general anesthesia which triggered a fatal hyperthermia. The 10 known MH reactors were persons who experienced a clinically recognized non-fatal MH episode after receiving general anesthesia. The 21 persons whose MH susceptibility was not known included: parents, siblings, and children of these 10 survivors.

Serologic testing for HLA antigens utilized the antibody-mediated lymphocyte microcytotoxicity assay;⁵ the standard NIH typing technique⁶ was used for all HLA determinations. Viable lymphocytes were typed for 16 A-locus, 18 B-locus, and 4 C-locus antigens using our local (Milwaukee County Medical Complex) typing plate. Antisera utilized included those identified in our laboratory, as well as antisera obtained from the NIH serum bank and other cooperating laboratories.

RESULTS

HLA typing indicated that among the 10 known MH reactors there were no individuals with an identical HLA type; only five pairs of individuals expressed one haplotype identity, albeit not the same haplotype. Thus, fifteen different haplotypes were identified within the reactor population. The lack of association between MH and HLA was shown by the absence of identical haplotypes within this extended family. This non-association is readily apparent in studying the haplotypes of the family unit shown in figure 2. While A.K., herself is not a known MH reactor, she represents a generation in which MH cases were clearly present. However, her grandson, D.K., a known MH reactor, did not inherit either of her HLA haplotypes.

Within the extended family (fig. 1), one family unit provided the opportunity for HLA typing in two sisters known to be MH reactors. This typing provided little evidence for association in that the shared haplotype: 28, 14, (W6), -, may well reflect the 50 per cent likelihood that siblings will have a common haplotype. Further lack of association was demonstrated by identical HLA haplotypes between one of the above siblings and another, non-reactor, sibling.

DISCUSSION

In a family having multiple case histories of a specific disease, any gene for disease-susceptibility, if it were associated with the HLA region, would be inherited as

* Visiting Professor, Department of Anesthesiology, The Medical College of Wisconsin, Milwaukee, Wisconsin.

† Chief, Diagnostic Immunology Laboratory, Department of Pathology, The Medical College of Wisconsin, Milwaukee, Wisconsin.

‡ Deceased; Late Professor and Chairman, Department of Anesthesiology, The Medical College of Wisconsin, Milwaukee, Wisconsin.

Address reprint requests to Dr. Irving Lutsky: Professor and Chairman, Department of Comparative Medicine, Hebrew University School of Medicine, Jerusalem, 91010 Israel. Accepted for publication September 1, 1981.

Key words: Hyperthermia: malignant. Immune response: HLA typing.

FIG. 1. Pedigree of a family with high MH susceptibility showing four MH fatalities (solid black) and ten suspected MH reactors (half black).

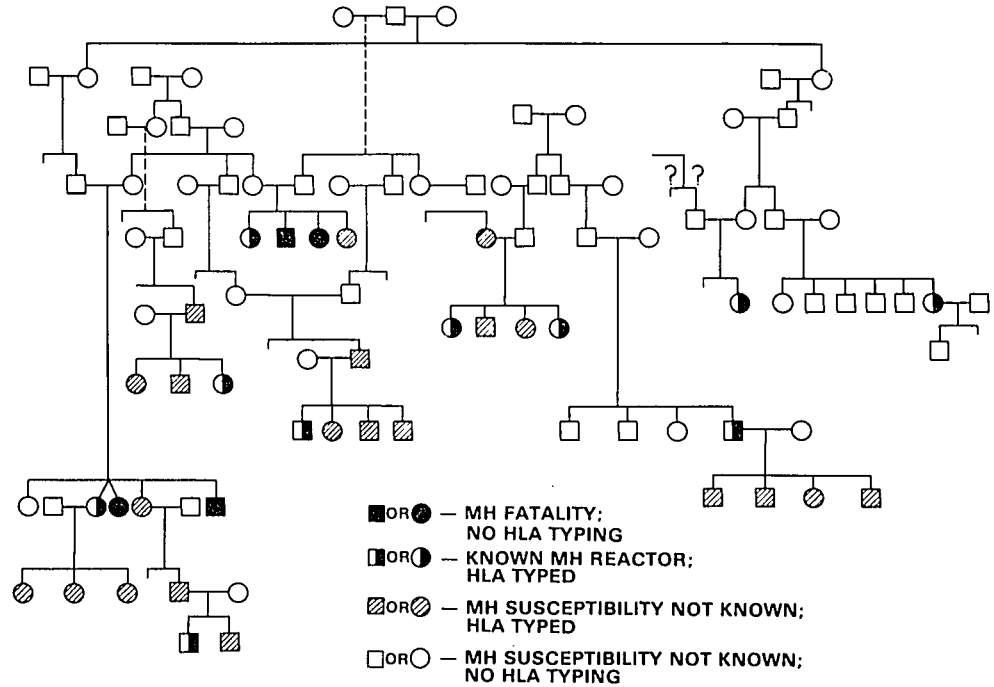
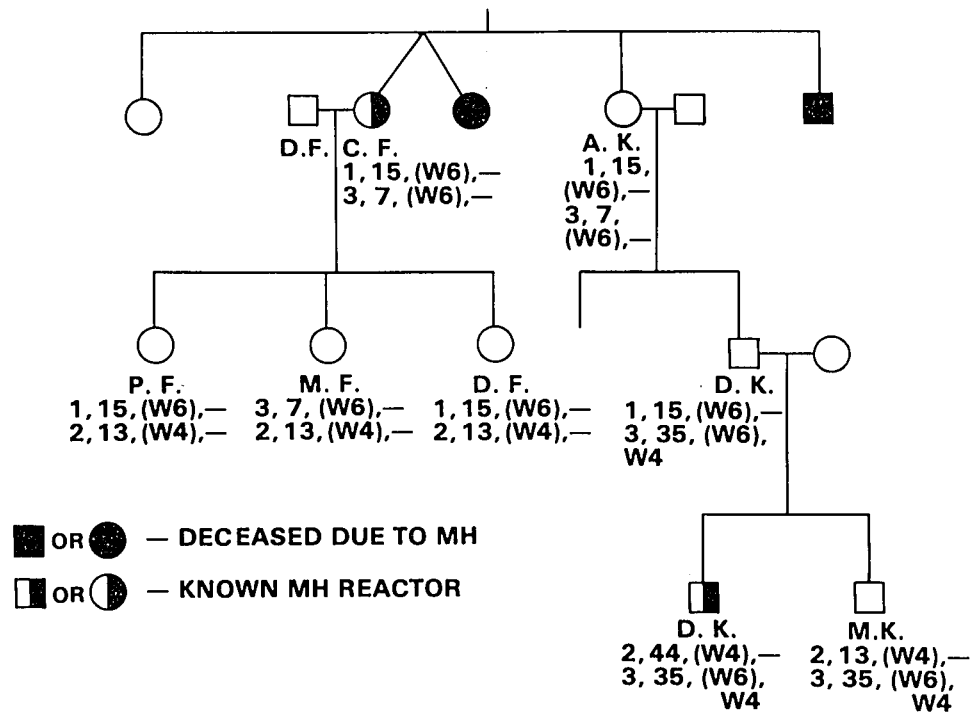

FIG. 2. Pedigree of a family unit with high MH susceptibility, showing HLA haplotypes listed according to HLA-A; HLA-B; HLA-C; and HLA-D specificities.



a HLA haplotype common to the affected individuals.⁷ Our findings do not show that any such association exists in the case of MH.

Studies of the possible association between HLA and disease susceptibility usually employ unaffected family members as the normal control population. Our comparison of antigen frequencies between MH reactors and

non-reactors in the same family showed no statistically significant differences. A further comparison of antigen frequencies between a panel of 17 MH reactors (10 distant relatives and seven unrelated) and a panel of 113 normal Caucasians as the control population showed no statistically significant *P* values on chi-square analysis after correction for the number of antigens tested.

We conclude that while MH is recognized as a latent genetic condition, susceptibility to this syndrome cannot be predicted on the basis of a distinctive or common HLA haplotype, since no such association was demonstrated in family members highly prone to this disease.

REFERENCES

1. Stephen CR: Malignant hyperpyrexia. *Annu Rev Med* 28:153-157, 1977
2. Ellis FR: Inherited muscle disease. *Br J Anaesth* 52:153-164, 1980
3. Henschel EO, Locher WG: The Wausau Story—malignant hyperthermia in Wisconsin, *Malignant Hyperthermia—Current Concepts*. Edited by Henschel EO. New York, Appleton-Century-Crofts, 1977, pp 3-7

4. Sasazuki T, McDevitt HO, Grumet FC: The association between genes in the major histocompatibility complex and disease susceptibility. *Annu Rev Med* 28:425-452, 1977
5. Mittal KK, Mickey MR, Singal DP, et al: Serotyping for homotransplantation. XVIII. Refinement of microdroplet lymphocyte cytotoxicity test. *Transplantation* 6:913-927, 1968
6. NIAID Manual of Tissue Typing Techniques, NIH Publication No. 80-545. Edited by Ray JG Jr. Bethesda, Md., U. S. DHEW, 1979, pp 39-41
7. Day NE, Simons MJ: Disease susceptibility genes—their identification by multiple case family studies. *Tissue Antigens* 8:109-119, 1976

Anesthesiology
56:226-228, 1982

Hyperkalemia: Benign, Hereditary, Autosomal Dominant

RAMARAO NAIDU, M.D.,* NINA L. STEG, M.D.,† G. DEAN MACEWEN, M.D.‡

The presence of hyperkalemia in a patient may present a medical emergency. The accepted normal value for serum potassium in individuals beyond the neonatal period is from 3.5 to 5.5 mEq/l. The narrow limit for this extracellular potassium is attributed to its rapid excretion by the kidney under the influence of adrenal hormone secretion. Serum levels can be lowered temporarily by administration of diuretics, or raised as a result of tissue damage. Persistent elevation of serum level is usually secondary to abnormalities such as Addison's disease, hyporeninemia, hypoaldosteronism, some forms of congenital adrenal hyperplasia, and renal failure.¹ Familial hyperkalemia with hypertension, hyporeninemia, and normal aldosterone levels was reported in four patients by Brautbar *et al.* in 1978.²

Pseudohyperkalemia is a condition in which serum potassium is elevated above normal values due to its release from the platelets, leukocytes, or erythrocytes during the clotting or separation process.³⁻⁶ Clinically, pseudohyperkalemia may be distinguished from hyperkalemia by estimating both plasma and serum levels. In pseudohyperkalemia, only the serum levels of potassium are high, while plasma levels remain normal.

Inherited pseudohyperkalemia caused by an abnormal leakage of potassium from erythrocytes was reported by Stewart *et al.* in 1979.⁷ The family of normokalemic subjects described had misleadingly high laboratory potassium levels. Serum potassium levels were normal when determined immediately after drawing, but rose in a linear direction to a very high level over a period of six hours of *in vitro* studies.

We report a family with true hyperkalemia not associated with hypertension or any detectable adrenal or renal abnormality. Neither the patient nor the members of his family appear to have clinical symptoms related to the presence of hyperkalemia.

REPORT OF A CASE

An 11-year-old boy with cerebral palsy, spastic paraplegia, and bilateral subluxation of the hips was admitted for bilateral varus osteotomy of the femur. He had been born prematurely; his mother had a significant antepartum hemorrhage. Birth weight was 1.62 kg. The patient was slow to reach developmental milestones, and the diagnosis of cerebral palsy was made at an early age. He had not walked without braces, and was usually confined to a wheelchair. Except for the usual childhood illnesses, he had no known medical problems other than those directly related to his cerebral palsy. His weight was 28.8 kg. (between the fifth and tenth percentile for his age) and his height was 133 cm (the fifth percentile for his age). His vital signs were within normal limits. Positive physical findings were limited to the motor system, which showed increased tone in all extremities. There were bilateral flexion contractures of the hips.

Routine preoperative laboratory studies revealed a normal complete blood count and urinalysis. Serum sodium was 140 mEq/l, potassium 6.3 mEq/l, total CO₂ 23.1 mEq/l, and chloride 108 mEq/l. These studies were repeated several times, and the abnormal serum potassium

* Chief of Anesthesiology, Alfred I. duPont Institute.

† Chief of Pediatrics, Alfred I. duPont Institute.

‡ Medical Director, Alfred I. duPont Institute.

Received from the Alfred I. duPont Institute, Wilmington, Delaware. Accepted for publication September 1, 1981.

Address reprint requests to: Dr. Ramarao Naidu, Alfred I. duPont Institute, P.O. Box 269, Wilmington, Delaware 19899.

Key words: Ions; electrolyte balance; potassium. Genetic factors.