

anesthesia.<sup>3</sup> More important, the diagnosis of anaphylactic shock was made rapidly on the basis of clinical signs and measurements from the arterial line, with immediate institution of intravenous therapy.

## REFERENCES

1. Saslow S: The cephalosporins. *Med Clin North Am* 54:1217-1228, 1970
2. Weinstein L, Kaplan K: The cephalosporins. *Ann Intern Med* 72:729-739, 1970
3. Spruill FG, Minette LJ, Sturmer WQ: Two surgical deaths associated with cephalothin. *JAMA* 229:440-441, 1974
4. Lockey RF, Bukantz SC: Allergic emergencies. *Med Clin North Am* 58:147-156, 1974
5. Sheffer AL: Treatment of anaphylaxis. *Postgrad Med* 53:62-66, 1973
6. Hanashiro PK, Weil MH: Anaphylactic shock in man; Report of two cases with detailed hemodynamic and metabolic studies. *Arch Intern Med* 119:129-140, 1967
7. Benner EJ: The cephalorin antibiotics. *Pediatr Clin North Am* 15:31-42, 1968
8. Scholand JF, Tennenbaum JI, Cerilli GJ: Anaphylaxis to cephalothin in a patient allergic to penicillin. *JAMA* 206:130-132, 1968
9. Rothschild PD, Doty DB: Cephalothin reactions after penicillin sensitization. *JAMA* 196:372-373, 1966
10. Kabins SA, Eisenstein B, Cohen S: Anaphylactoid reaction to an initial dose of sodium cephalothin. *JAMA* 193:165-166, 1965
11. Kelley AJ: Anaphylaxis under anesthesia (correspondence). *Anaesth Intensive Care* 1:332, 1973
12. Driggs RL, O'Day RA: Acute allergic reaction associated with methohexital anesthesia: Six cases. *J Oral Surg* 30:906-909, 1972
13. Katz AM, Battit GE, Wilkey BR: An anaphylactoid reaction to penicillin during anesthesia. *ANESTHESIOLOGY* 32:84-86, 1970
14. Bruce DL, Wingard DW: Anesthesia and the immune response. *ANESTHESIOLOGY* 34:271-282, 1971

## A Simple Pressure-relief Valve to Prevent Increases in Endotracheal Tube Cuff Pressure and Volume in Intubated Patients

THEODORE H. STANLEY, M.D.,\* JERROLD L. FOOTE, B.S.,† WEN-SHIN LIU, M.D.‡

Recent experiments *in vitro*<sup>1,2</sup> and in patients with endotracheal tubes in place<sup>3,4</sup> have demonstrated that oxygen and anesthetic gases diffuse into endotracheal-tube cuffs more rapidly than the nitrogen of the air-filled cuffs diffuses out. The result is that cuff volumes and pressures may markedly increase with time. An overinflated cuff can compress the wall of an endotracheal tube or cover its orifice and produce upper airway obstruction.<sup>5-7</sup> Overinflated cuffs also result in high cuff pressures.<sup>8</sup> The latter may be associated with an increased incidence of

tracheal trauma.<sup>5,8</sup> In order to avoid these problems, we have suggested that cuffs be frequently deflated or be filled with a sample of the inspired mixture of gases rather than room air.<sup>3,4</sup> Another alternative is a pressure-relief valve which, when attached to the cuff catheter, will bleed off excess cuff gases but maintain cuff volume and pressure required for seal. We have designed a simple variable-pressure-relief valve, which has prevented increases in cuff volume and pressure and maintained cuff seal in 39 anesthetized patients during operations lasting as long as six hours.

The valve (fig. 1) is made of polycarbonate in the shape of a "T." One end of the cross portion of the "T" (fig. 2) is molded in the form of a standard male Luer fitting and is designed to be attached to the tip of an endotracheal-tube-cuff inflating catheter. This end of the "T" communicates with the other end through a hollow *body*. The second end of the cross of the "T" contains a spring-loaded check valve, which remains closed

\* Associate Professor of Anesthesiology.

† Biophysicist, Division of Artificial Organs.

‡ Fellow in Anesthesiology and Artificial Organs.

Received from the Department of Anesthesiology and Division of Artificial Organs, University of Utah College of Medicine, 50 North Medical Drive, Salt Lake City, Utah 84132. Accepted for publication March 30, 1975. Presented in part at Tenth Annual Meeting of the Association for the Advancement of Medical Instrumentation, Boston, March 1975.

Address reprint requests to Dr. Stanley.

until a syringe is placed into the female Luer fitting located at this end. The check valve prevents passage of inflating gas except when a syringe is connected to the fitting for inflation or deflation of the cuff.

The upright portion of the "T" (the body) contains the pressure-relief valve mechanism. This consists of a latex rubber stopper supported by a precision spring. The latter is held in place by a cap built with threads that match threads on the valve body, thus allowing the cap to be screwed onto the body. The cap contains two vent holes and an index mark. The index mark is designed so that it can be aligned with one of eight pressure-relief set-point markings located around the periphery of the body. The cap also contains a protruded region central to the spring which is of sufficient length so that when the cap is rotated clockwise as far as possible, the protrusion presses against the back side of the rubber stopper, preventing the escape of cuff gas regardless of cuff pressure.

Alignment of the index mark on the cap with one of the eight pressure-relief set-point markings around the periphery of the body establishes the pressure at which bleed-off occurs from the valve. The set-point markings have been calibrated for pressure relief at 25, 50, 75, 100, 125, 150, 175, and 200 mm Hg. These plus the "off" position previously described give a total of nine possible choices. The valve is not calibrated for bleed-off at other pressures, but pressure relief at other pressures between 25 and 200 mm Hg can be approximated by setting the cap index mark positions between the eight pressure-relief set-point markings.

The valve is operated by placing its male Luer fitting into the tip of the endotracheal-tube-cuff catheter after intubation but before cuff inflation. With the valve's cap index mark set to the "off" position, the cuff is inflated through the valve until cuff seal occurs. The cap index mark is then aligned with the lowest pressure-relief set point that allows cuff seal to be maintained.

The pressure-relief valve was studied in 39 anesthetized patients who were undergoing a variety of general surgical or orthopedic operations. Portex endotracheal tubes

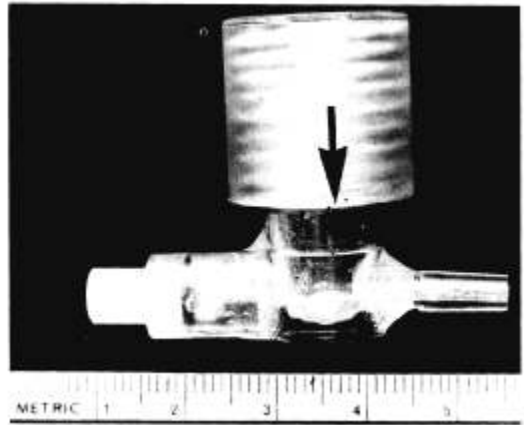

FIG. 1. Adjustable endotracheal-tube-cuff catheter pressure-relief valve.

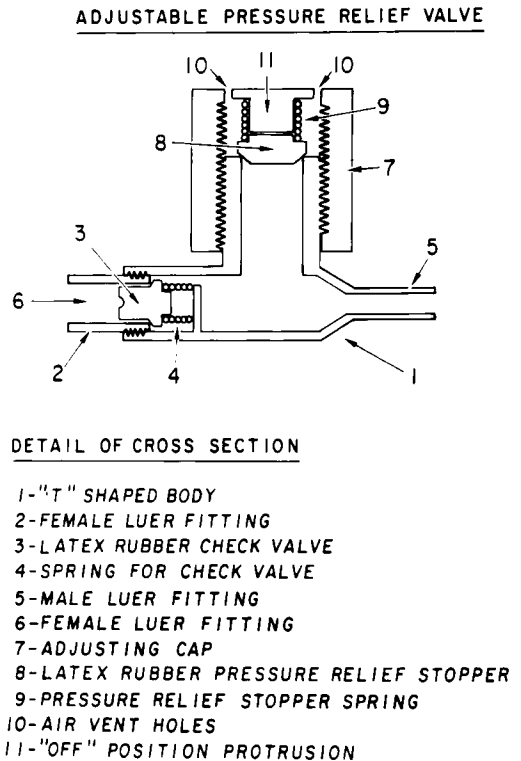

FIG. 2. Detail of pressure-relief valve.

were used with high-residual-volume, low-pressure cuffs or low-residual-volume, high-pressure cuffs. Anesthesia was induced with thiopental. The patients were paralyzed with succinylcholine and their tracheas intubated. After intubation and before

TABLE 1. Volumes and Pressures of Portex Cuffs with a Pressure-relief Valve Attached to the Cuff Catheter before and after Anesthesia with 60 Per Cent Nitrous Oxide, Enflurane, and Oxygen in 39 Intubated Patients (Means  $\pm$  SD)

Cuff	Time (Min)	Initial Cuff Volume (ml)	Final Cuff Volume (ml)	Volume Change (ml)	Initial Cuff Pressure (mm Hg)	Final Cuff Pressure (mm Hg)	Pressure Change (mm Hg)
Endotracheal tubes with low-pressure cuffs	109 $\pm$ 19	4.9 $\pm$ 1.7	5.1 $\pm$ 1.5	+0.2 $\pm$ 0.3	68 $\pm$ 15	65 $\pm$ 10	-3 $\pm$ 3
Endotracheal tubes with high-pressure cuffs	113 $\pm$ 26	5.4 $\pm$ 2.1	5.5 $\pm$ 1.7	+0.1 $\pm$ 0.2	119* $\pm$ 29	121* $\pm$ 26	+2 $\pm$ 4

\*  $P < 0.001$ , Student's *t* test, compared with low-pressure cuff values.

succinylcholine-induced paralysis disappeared, the pressure-relief valve was attached to the endotracheal-tube-cuff catheter, the cuff was filled with air until sealing was achieved, and the valve-cap index mark was aligned with one of the body set-point markings as previously described. Cuff gas inflating volumes were then measured with a calibrated syringe and cuff pressures with a calibrated standard pressure transducer or sphygmomanometer attached to the tip of the cuff catheter. Anesthesia was maintained with 60 per cent nitrous oxide, 38–40 per cent oxygen, intermittent 1–6-mg doses of pancuronium, and 1–2 per cent halothane. The above-described cuff volume and pressure measurements were repeated at the conclusion of the operative procedure before pancuronium-induced muscle relaxation was reversed. Gas obtained from the cuffs of ten patients was analyzed for oxygen, nitrogen and nitrous oxide on a Hewlett-Packard gas chromatograph.

Patients intubated with low-pressure-cuffed endotracheal tubes (19 patients) had similar initial cuff volumes but lower initial cuff pressures than patients intubated with tubes with high-pressure cuffs (20 patients) (table 1). The two groups of patients had similar intubation times. Cuff volumes and pressures of the two groups at the end of the operative procedure were not significantly different from their respective initial values. Analysis of gas from the cuffs revealed that 30–40 per cent of that in the cuffs at the end of operation was nitrous oxide.

In a previous report we demonstrated that approximately two hours of anesthesia with 60 per cent nitrous oxide and oxygen will

increase volumes and pressures of Portex low- and high-pressure endotracheal tube cuffs.<sup>3</sup> We showed that these changes were the result of diffusion of nitrous oxide and to some extent oxygen into the cuffs and the absence of nitrogen diffusion out of the cuffs. In a subsequent study we found that the simple procedure of inflating cuffs with a sample of the inspired gases prevented gas diffusion into cuffs and cuff volume and pressure changes.<sup>4</sup> This study indicates that endotracheal-tube-cuff overinflation and pressure build-up during anesthesia can also be prevented by attaching a simple, variable-pressure-relief valve to the cuff catheter. While cuff gas analysis showed that nitrous oxide still diffuses into cuffs attached to our pressure-relief valves, bleed-off through the valve eliminates any cuff pressure or volume change. The obvious advantage of use of the pressure-relief valve over that of filling cuffs with a sample of the inspired gases is that cuffs do not have to be deflated and reinflated each time the anesthetic is changed or anesthetic and oxygen concentrations are changed. The valve should also be effective in preventing cuff overinflation in intubated patients subjected to sudden decreases in atmospheric pressure, such as those that occur during air evacuation of intubated patients.

*In-vitro* and clinical testing has demonstrated that our pressure-relief valve can be attached to and is effective in preventing pressure and volume changes in the cuffs of all currently available commercial endotracheal tubes (Stanley, unpublished data). In tubes with built-in cuff-catheter valves the male Luer fitting of our valve renders

the cuff-catheter valve incompetent. In tubes without built-in cuff-catheter valves our valve replaces a hemostat or clamp.

REFERENCES

1. Stanley TH, Kawamura R, Graves C: Effects of nitrous oxide on volume and pressure of endotracheal tube cuffs. *ANESTHESIOLOGY* 41:256-262, 1974
2. Stanley TH: Effects of anesthetic gases on endotracheal tube cuff gas volumes. *Anesth Analg (Cleve)* 53:480-482, 1974
3. Stanley TH: Nitrous oxide and the pressure and volume of high- and low-pressure endotracheal-tube cuffs in intubated patients. *ANESTHESIOLOGY* 42:637-640, 1975
4. Stanley TH, Liu WS: Tracheostomy and endotracheal tube cuff volume and pressure changes during thoracic surgery. *Ann Thorac Surg* (in press)
5. Adriani J, Phillips M: Use of the endotracheal cuff: Some data pro and con. *ANESTHESIOLOGY* 18:1-4, 1957
6. Lopez G, James NR: Mechanical problems of the airway, *Clinical Anesthesia, Common and Uncommon Problems in Anesthesiology*. Edited by MT Jenkins. New York, F. A. Davis, 1968, pp 17-20
7. Forrester AC: Mishaps in anesthesia. *Anaesthesia* 14:388-398, 1959
8. Carroll R, Hedden M, Safar P: Intratracheal cuffs: Performance characteristics. *ANESTHESIOLOGY* 31:275-281, 1969

## Preoperative CC/FRC Ratio and Postoperative Hypoxemia

EUGENE E. FIBUCH, M.D.,\* KAI REHDER, M.D.,† ALAN D. SESSLER, M.D.†

Postoperative hypoxemia has been described by many observers,<sup>1-4</sup> but its mechanisms are still not clearly understood. Recently, Spence<sup>5</sup> and Alexander<sup>6,7</sup> and their co-workers proposed that "airway closure" may be in part responsible. These authors based their hypothesis on the observation that, postoperatively, the functional residual capacity (FRC) is decreased more than the closing capacity (CC)†; hence, the CC/FRC ratio increased. Craig and co-workers<sup>8</sup> had demonstrated earlier that an increase in the CC/FRC ratio may result in impaired arterial oxygenation.

It is known that, beginning at approximately 44 years of age, "airway closure" may occur within the breathing range in normal subjects in the supine position.<sup>9</sup> Therefore, patients beyond this age may have some lung regions

with low  $\dot{V}/\dot{Q}$  ratios and possibly also increased intrapulmonary right-to-left shunting ( $\dot{Q}_S/\dot{Q}_T$ ) caused by "airway closure." If the CC/FRC ratio increases postoperatively, increased inequalities of  $\dot{V}/\dot{Q}$  ratios and increased  $\dot{Q}_S/\dot{Q}_T$  may develop. Because Alexander and co-workers<sup>6</sup> made their measurements of the alveolar-arterial oxygen tension difference ( $P[A-aD_{O_2}]$ ) in subjects breathing room air, they could not distinguish between the effects of the increased CC/FRC ratio

ABBREVIATIONS

- CC = closing capacity
- FRC = functional residual capacity
- RV = residual volume
- TLC = total lung capacity
- CV = closing volume
- $P_{aO_2}$  = arterial oxygen tension
- $P_{aCO_2}$  = arterial carbon dioxide tension
- $P[A-aD_{O_2}]^{1,0}$  = alveolar-arterial oxygen tension difference determined during oxygen breathing
- $\dot{V}/\dot{Q}$  = ventilation-perfusion ratio
- $\dot{Q}_S/\dot{Q}_T$  = intrapulmonary right-to-left shunting
- $P_B$  = barometric pressure
- $P_{H_2O}$  = water vapor tension
- $V_T$  = tidal volume

\* Chief Resident Associate, Mayo Clinic and Mayo Foundation, Rochester, Minnesota.

† Associate Professor of Anesthesiology, Mayo Medical School, Rochester, Minnesota.

Accepted for publication April 2, 1975. Supported in part by Research Grant HL-12090 from the National Institutes of Health, Public Health Service, and by a grant from the Parker B. Francis Foundation, Kansas City, Missouri.

Address reprint requests to Dr. Rehder: Mayo Clinic, 200 First Street SW, Rochester, Minnesota 55901.

† Closing capacity is the absolute lung volume at which "airway closure" begins to occur.