

Current Comment

S. G. HERSHEY, M.D., *Editor*

The Use of Data Tape Recording as a Teaching Aid

DAVID GOWING, M.D.,* AND FREDERICK P. HAUGEN, M.D.†

The recording of data on magnetic tape is not by any means new, having been used for years in computer and telemetry data storage systems. More recently, excellent, albeit very costly, data tape recording systems have been employed in biomedical laboratories for physiological data recording. The expense involved, however, has more or less precluded the use of this valuable tool as a means of preservation and presentation of ECG's and EEG's as a teaching adjunct. Nonetheless, equipment which will give a reasonable quality reproduction of tracings may be assembled quite inexpensively.

THEORY

A tape recorder cannot be used for direct recording of ECG or EEG signals because of inadequate low-frequency response. Use of a carrier tone extends low-frequency response down to d.c., but imposes an upper-frequency limit. For ECG recording, the high-frequency cutoff need not be more than 300 c.p.s. In commercial data recording systems, the carrier tone is usually frequency-modulated. This affords relative immunity from noise and gives wide dynamic range, but requires very constant tape speed so that spurious variations in frequency will not occur. In addition, the circuits used for playback are costly, quite critical, and readily become de-aligned if the equipment is roughly handled. An AM system, although it has less immunity to noise and less dynamic range, is simple and inexpensive, and will tolerate handling well. For adequate reproduction, the carrier frequency must be at least ten and

preferably one hundred times as high as the highest frequency to be encountered in the modulating signal (in this case, ECG). Therefore, the carrier frequency needs to be at least 3,000 c.p.s., but as much higher as the frequency response of the tape recorder will permit. It is also wise to use recording tape of reasonable quality, so as to avoid nonuniformities in the thickness of the oxide coating with consequent spurious amplitude variations.

CIRCUIT

The carrier tone, generated by a suitable oscillator, is applied to the control grid of a pentode (6AU6) as shown in figure 1. The suppressor grid is biased so that the output of the carrier tone is 50 per cent of maximum when no ECG is being applied. The ECG signal (which in our system was taken from the "recorder" jack of an ORM-1 cardioscope) is applied to the suppressor grid after amplification to about 30 volts magnitude. The ECG amplitude may be adjusted so that the 1-millivolt standard pulse produces 60-70 per cent modulation of the carrier tone. The output of the tube is then fed to the tape recorder. Any machine capable of handling music without obvious distortion is satisfactory.

Figure 2 shows a diode demodulator circuit for playback. The setting of potentiometer R_1 governs waveform; the setting of R_2 governs output amplitude. R_1 should be adjusted for best reproduction of a tape-recorded test signal. A slow rectangular wave is excellent for this purpose.

APPLICATION

The foregoing technique easily permits the continuous recording of an ECG throughout an operation. Arrhythmias occurring during

* Assistant Professor of Anesthesiology at the University of Oregon Medical School.

† Professor of Anesthesiology at the University of Oregon Medical School, Portland, Oregon.

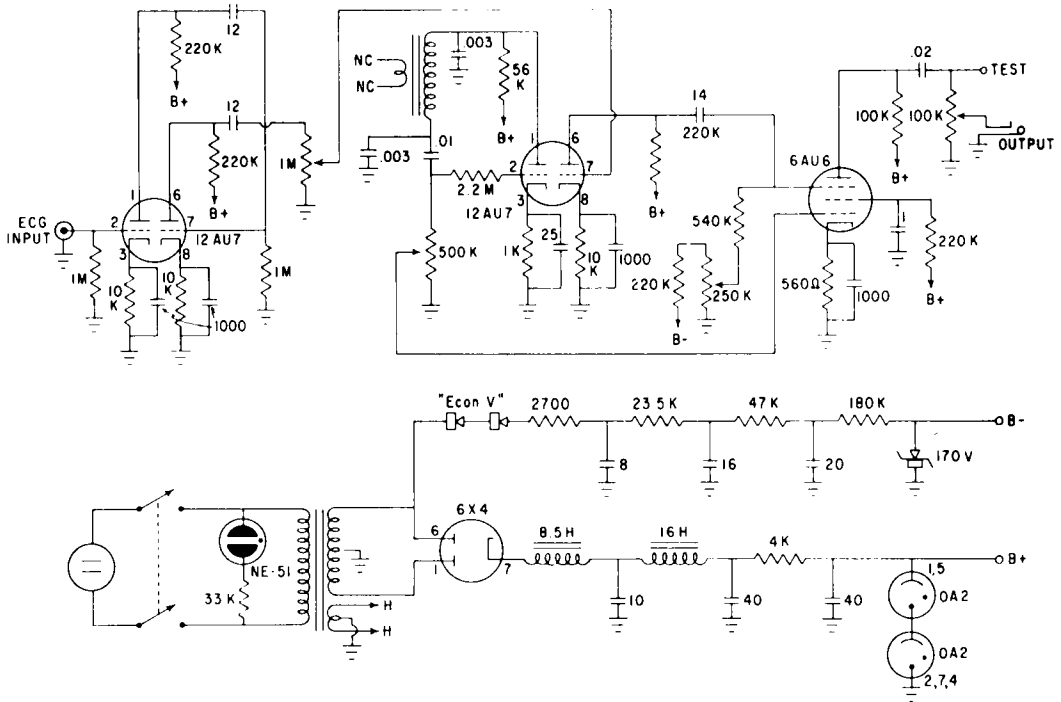

FIG. 1. Circuit diagram of carrier recording amplifier.

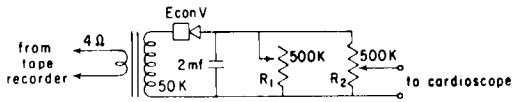

FIG. 2. Demodulator circuit.

this time may be subsequently reviewed for purposes of study and instruction. Playback may be made into an oscilloscope, cardioscope, or conventional ECG machine. Use of a

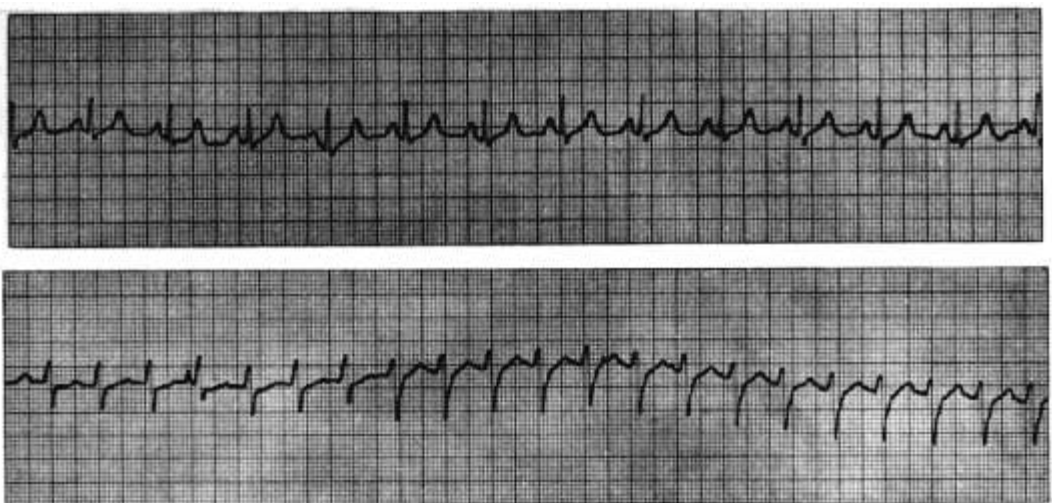

FIG. 3. Top: Electrocardiogram, lead 2. Bottom: Electrocardiogram, lead 2, showing the development of a supra-ventricular tachycardia in an elderly digitalized patient during cyclopropane anesthesia.

stereo tape recorder provides a sound track for verbal description of events of interest and their management. By employing a combination of oscilloscope and ECG machine, portions of special interest may be located and paper tracings made. Should a patient suffer a cardiac catastrophe during the immediate postoperative period, the entire tracing may be

reviewed in detail to see whether or not a recognizable cardiac insult occurred during operation.

To date, we have recorded tracings from about thirty patients. Two sample tracings are shown (fig. 3).

This study was supported by Grant GT-665 USPHS.

Effects on Postoperative Sore Throats of Two Analgesic Agents and Lubricants Used with Endotracheal Tubes

LAWRENCE O. LUND, M.D.,* AND FELISARING G. DAOS, M.D.†

Because previous observations on the use of lubricant vehicles, specific local analgesic agents, and topical use of hydrocortisone have not shown significant decreases in symptoms of sore throats after endotracheal intubation, a study was undertaken to attempt to find whether the use of a light or viscous base with or without lidocaine or pramoxine would show differences in incidence of this symptom.

METHOD

One thousand twenty-five patients ranging from 5 to 75 years of age who underwent general anesthesia during which an endotracheal tube was used were studied over a four-month period. Four groups of approximately 200 each were composed of patients for whom one lubricant, either light or heavy base and with or without a local analgesic agent was used. An endotracheal tube was used for an additional group but no lubricant was employed. Because of schedule changes such as postponements, cancellations and emergencies and because the patients who might have nasogastric tubes were unknown at the time of premedication and selection, the assignment of various lubricants to specific patients in a statistically randomized manner was not attempted. Two hundred fifty tubes of lubri-

cants used were coded by number which was recorded on an individual reference card. At the end of the study the unknown materials were identified. This was a double blind study except that those who performed the intubation knew whether a light or heavy lubricant was being used. They did not know whether an analgesic agent was included. Patients were interviewed by one of two third-year resident anesthesiologists. After several non-specific questions concerning their postoperative course, the patients were asked directly about specific complaints referable to the throat.

The patients were included in the study on the basis of their consecutive arrival in the operating room, except for those who had pre-existing upper respiratory infection, sore throat, hoarseness, operative procedures which would manipulate the endotracheal tubes such as radical neck procedures, or those with nasogastric tubes. No subjects were included in the results where multiple attempts were required for intubation, or if any blood appeared on withdrawal of the laryngoscope. The distribution of patients was comparable in each of the five groups, and included those having procedures in general, thoracic, urologic, gynecologic, neurologic, and orthopedic surgery. Patients were seen at least on the first postoperative day and until their complaints improved, if present. No attempts were made to evaluate the severity of their complaints and

* Division of Anesthesiology, University of Colorado Medical Center, Denver, Colorado.

† Present Address: Tarlac, Tarlac, Philippines; recipient of Fellowship from Burroughs-Wellcome and Company.