

mals, or carried around by a cockroach.<sup>9</sup> The possibilities are infinite.

Another advantage of radio telemetry in physiological monitoring lies in the fact that, using standard subcarrier techniques, it is quite feasible to use commercial tape or belt recording systems for recording, playback and storage of physiological data at a considerable saving of time and money.

At this time, radio telemetry as a tool in physiological monitoring is at least twenty-five years behind the applications of radio telemetry in other fields. It is not yet fool-proof. Its use offers many advantages, and its possibilities are tremendous. If this technique gains popular appeal, it will be most interesting to watch its future development.

REFERENCES

1. Nichols, M. H., and Rauch, L. L.: *Radio Telemetry*, ed. 2. New York, John Wiley & Sons, 1956.

2. Barr, N. L.: Radio transmission of physiological information, *Milit. Surg.* **114**: 79, 1954.  
 3. Holter, N. J.: Radioelectrocardiography: new technique for cardiovascular studies, *Ann. N. Y. Acad. Sci.* **65**: 913, 1957.  
 4. Farrar, J. T., Zworykin, V. K., and Baum, J.: Pressure-sensitive telemetering capsule for study of gastrointestinal motility, *Science* **126**: 975, 1957.  
 5. Webb, J. C., Campbell, L. E., and Hartsock, J. G.: *Electrocardiograph telemetering (radio)*, 1958 I. R. E. National Convention Record, part 9, pp. 43-49, March, 1958.  
 6. Beenken, H. G., and Dunn, F. L.: Short distance radio telemetering of physiological information, I. R. E. Transactions on Medical Electronics, PGME-12, pp. 53-57, December, 1958.  
 7. Dunn, F. L., and Beenken, H. G.: Short distance radio telemetering of physiological information, *J. A. M. A.* **169**: 1118, 1959.  
 8. Essler, W. O., and Folk, G. E., Jr.: Monitoring heart rates and body temperatures of unrestrained mammals by radio transmitter, *Anat. Rec.* **137**: 353, 1960.  
 9. Readout 3: 3134, Ampex Instrumentation Products Company, Redwood City, California, April-May, 1961.

Efficacy of Oxygen Administration

Dr. Thomas F. Hornbein of Washington University School of Medicine, St. Louis, Missouri, evaluated the relative efficiency of a nasal oxygen catheter and K-S disposable oxygen mask (Ohio) for administration of oxygen by comparison of alveolar oxygen tensions in a conscious, resting subject. Alveolar oxygen tensions were measured by elution of 40-cu. mm. aliquots of Haldane samples in a gas chromatograph.

The advantage of the mask results from re-breathing of oxygen-enriched expired air in addition to the basal oxygen flow. Accumula-

tion of carbon dioxide is minimized by re-breathing into a bag of small volume which is washed out by an adequate flow of oxygen.

	Alveolar Po <sub>2</sub> (mm. Hg) at Oxygen Flow of:	
	4l/minute	6l/minute
Nasal Catheter	210	270
Disposable Mask	350	425

The greater comfort of the mask should also be mentioned, especially as compared to the sensations resulting from administration of high oxygen flows through a nasal catheter.

Meperidine and Propiomazine for Preanesthetic Medication

Captain Paul Davis and Lt. Col. John A. Jenicek of Brook General Hospital in San Antonio, Texas, while utilizing a double blind technique, gave two groups (40 in each) of patients preanesthetic medication on the following basis: one group, meperidine, 0.5 mg. per pound and propiomazine (Largon) 0.15 mg. per pound, the second group only meperidine, 0.5 mg. per pound. The factors of age,

weight, sex and sampling were sufficiently controlled so that subjective and objective data obtained could be statistically analyzed.

The subjective factors of general effect, sedation, presence of apprehension, and ease of induction showed no significant differences in either group. The objective differences considered were respiratory rate, minute volume, tidal volume, and alveolar ventilation. Calcula-

lated  $V_a - (TV - RDS)RR$ ; where  $V_a$  is alveolar ventilation;  $TV$ , tidal volume;  $RDS$ , respiratory dead space, and  $RR$ , respiratory rate.

The respiratory rate, tidal volume, and minute volume were measured using a Collins 9.5-liter spirometer and a permanent record made.

The respiratory rate was not changed by either schedule. The minute volume, tidal volume, and alveolar ventilation were significantly depressed by both drug schedules. These same parameters demonstrated differences between the schedules applied. The differences were evaluated by analysis of variance and were found to be statistically significant: ( $0.05 < P > 0.01$ ) for the 5 per cent level, ( $0.01 < P > 0.001$ ) for the 1 per cent

level. Greater depression was produced by meperidine alone.

The sedative effect of both drug schedules was the same. There was less respiratory depression of the patients who received propiomazine in addition to the meperidine. This was an interesting and unexpected finding. The spirometer tracings gave no indication of irregularity or of variations during the breathing tests. Since there is little in the literature about the effects of propiomazine, this brief report is made to indicate further lines of investigation which may be followed.

The views and opinions expressed herein do not necessarily represent those of the Surgeon General, The Department of The Army, or the Department of Defense.

## GADGETS

### New Vaporizer for Volatile Agents

Dr. James A. Felts of Herrin Hospital in Herrin, Illinois, and the Holden Hospital, Carbondale, Illinois, has devised a new vaporizer for use with volatile anesthetic agents. This vaporizer, and its earlier models, has been in use since March, 1960. It is designed for a technique, to be described fully in a separate paper, in which diethyl ether or halothane are intermittently injected in true closed circuit anesthesia, using metabolic flows of oxygen. In this technique, diethyl ether or halothane are admitted to the vaporizer by syringe in closely controlled increments related to the patient's body weight and to the time elapsed. Succinylcholine chloride is simultaneously administered by intravenous drip, also in amounts related to the patient's body weight and to the time elapsed. The vaporizer is not limited to this particular technique, however. Any volatile agent may be used, if it is adaptable to a closed system. The device is coupled to the exhalation port of the anesthesia apparatus.

The vaporizer, shown in side view in figure 1, consists of a base through which the exhaled atmosphere passes, a vaporizing core, and a surrounding jacket.

Figures 2 and 3 are cross sections through portions of the base.

(A in figure 1), and one for attachment of the exhalation tubing (B in figure 1), the apparatus is made of copper, taking advantage of the superior heat transfer properties of this metal. The adapters, since they are subject to stress and manipulation, are made of more durable brass.

The passage in the base, through which the exhaled atmosphere flows, consists of two chambers, shown in figure 1 as C and D. The chamber nearest the patient (C) is a high

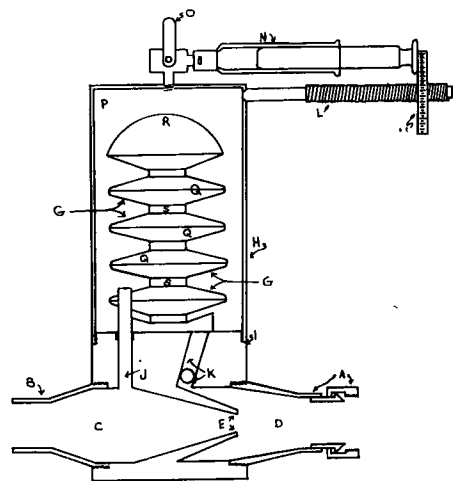

FIG. 1. Side cross section of vaporizer.