

Lüer's Lure

From an International Standards Perspective

Debra R. Milamed, M.S.,* Karen Brown, M.D.,† Edward Murphy, M.B.B.S.‡

Small-bore Connectors: The Lüer Controversy

The Luer connector, a specific type of small-bore connector, is encountered daily in clinical practice. The familiar Luer 6% taper male (slip), and the Luer-locking mechanism (LUER-LOK, Becton Dickinson, Franklin Lakes, NJ) have been used for nearly a century in a wide range of intravenous, neuraxial, enteral, airway and other medical applications. The Luer design began in 1897 when Hermann W. Lüer filed U.S. patent no. 583,382¹ for his hypodermic precision ground-glass syringe. In 1925 Fairleigh S. Dickinson filed U.S. patent no. 1,742,497² for a modification of Lüer's syringe (fig. 1). The modification included a 6% taper and a novel sleeve-carrying component, element 5 in figure 1. The spiral cams, elements 9 and 10 in figure 1, were spaced a sufficient distance apart to permit the hub to freely rotate until it began to frictionally engage with the outer surface of the nozzle, element 2. The novel locking

element was subsequently named the LUER-LOK (Becton Dickinson).² The LUER-LOK proved so successful that it is now ubiquitous in medical practice, providing a secure, yet easily detachable connection in intravenous, neuraxial, enteral and airway equipment. Indeed, it is estimated that as many as 40 such small-bore connectors may be used in a single cardiac patient.³

The universality of this internationally standardized fitting has, however, enabled misconnection between medical equipment, resulting in patient harm and death.⁴⁻⁶ Block *et al.*⁷ suggest that the Luer connection is a leading common root cause of misconnection/wrong-route administration incidents. The ECRI Institute (formerly Emergency Care Research Institute, a nonprofit organization for evaluating medical equipment safety, and publisher of the journal *Health Devices*) has listed the Luer connector as one of "the Top 10 Health Technology Hazards."⁸ Nearly a century after its invention, the Luer small-bore connector is at the center of a maelstrom of controversy. Risk managers and regulators have called for a redesign of the Luer small-bore connector system and development of the relevant International Standards to safeguard against misconnection.

* Associate in Anaesthesia, Harvard Medical School, Boston, Massachusetts. † Professor, Queen Elizabeth Foundation Chair in Pediatric Anesthesia, Division of Pediatric Anesthesia, McGill University Health Center/Montreal Children's Hospital, Montreal, Quebec, Canada. ‡ Clinical Senior Lecturer, Acute Care Medicine, University of Adelaide, Staff Specialist Anaesthetist, Department of Anaesthesia, Royal Adelaide Hospital, Adelaide, South Australia.

Received from the Department of Anaesthesia, Harvard Medical School, Boston, Massachusetts; Division of Pediatric Anesthesia, McGill University Health Center, Montreal Children's Hospital, Montreal, Quebec, Canada; and Department of Anaesthesia, Royal Adelaide Hospital, University of Adelaide, Adelaide, Australia. Submitted for publication March 9, 2012. Accepted for publication September 5, 2012. D. R. Milamed is supported by the David S. Sheridan Professorship of Harvard University, Cambridge, Massachusetts; Prof. Brown is supported by the Queen Elizabeth Hospital of Montreal Foundation Chair in Pediatric Anesthesia, Montreal, Quebec, Canada; and Dr. Murphy is supported by the South Australian Department of Health and University of Adelaide, Adelaide, South Australia, Australia.

Address correspondence to D. R. Milamed: Department of Anaesthesia, Harvard Medical School, 1400 VFW Parkway, Boston, Massachusetts 02132-4927. debra_milamed@hms.harvard.edu. This article may be accessed for personal use at no charge through the Journal Web site, www.anesthesiology.org.

Clinical Reports of Luer Misconnections

Over the last four decades more than 200 tubing and catheter misconnections have been reported. A search for "misconnections of tubes carrying feedings intended for enteral routes, to intravenous lines" yielded 34 publications (misconnections = 116) between 1972 and 2010.⁹ The World Health Organization reported 58 cases of inadvertent intrathecal administration of vincristine from 1968 to 2007, which had catastrophic consequences.¹⁰ The United Kingdom National Patient Safety Agency reported 32 inadvertent administrations of enteral preparations into central intravenous lines between 2003 and 2007.¹¹ As of April 2006, the Joint Commission's (formerly Joint Commission on the Accreditation of Healthcare Organizations, or JCAHO) Sentinel Events Database reported nine inadvertent misconnections between varied tubings.¹² A U.S. Pharmacopeia review of more than 300 cases reported to its MEDMARX® and the U.S. Pharmacopeia Institute for Safe Medication Practices Medication Errors Reporting Program databases revealed numerous

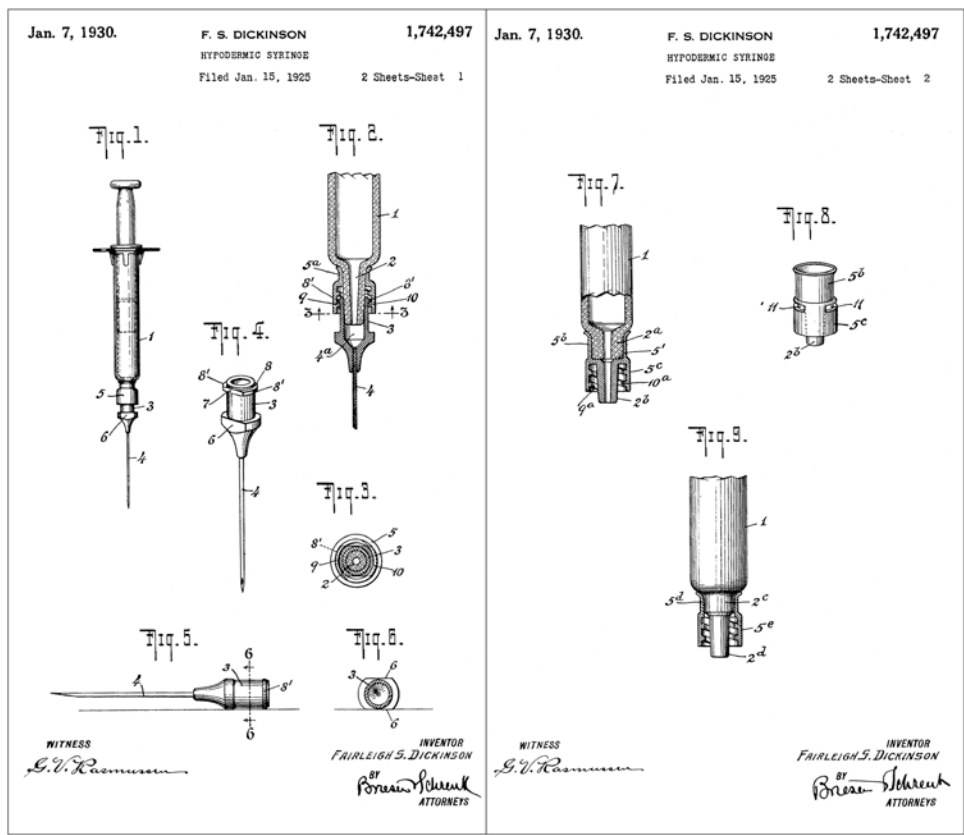

Fig. 1. In his January 15, 1925 U.S. Patent Application, Fairleigh S. Dickinson wrote that "the new invention overcomes all the difficulties and disadvantages of the prior constructions, while at the same time retaining all of the advantages thereof. These results are brought about by constructing the needle member so that, while it still may be efficiently utilized in connection with the barrel members of existing syringes of the indicated type in a manner to retain all of the advantages inherent therein, it is specially adapted for use in connection with the barrel of the new syringe which includes means arranged to cooperate with means on the needle, so located with respect to each other so as to prevent unintentional separation of the needle and barrel and to emphasize the desirable features which are found in the existing syringes. In the illustrated example of the invention (Fig. 2), the syringe is provided with a sleeve-carrying element supporting the locking sleeve 5, said element being secured in place in any suitable manner upon the syringe, the method of attachment being such as to withstand separation of the parts under any ordinary conditions to which the syringe is subjected. A preferred method of accomplishing this result is to make the collar 5^a [in drawing labeled Fig. 2 of Fig. 1] of the metal sleeve 5 slightly smaller in internal dimension than the exterior dimension of the ground glass nozzle 2 at its point of connection with said collar 5^a, then heating the latter and in its heated condition slipping it upon the relatively cool glass nozzle 2 whereupon as the metal cools a practically permanent connection will be established..."²

misconnections involving Luer connectors and prompted a 2008 Policy Statement from the U.S. Pharmacopeia Safe Medication Use Expert Committee.¹³

It is widely held that misconnections between the Luer small-bore connectors are underreported. This limits the ability of epidemiologists and regulators to investigate the problem.¹⁴ Furthermore, reports are often incomplete. A recent U.S. Department of Health and Human Services assessment of adverse events in hospitals could not distinguish tube or catheter misconnections among its 36 categories of adverse events.¹⁵

The Need for International Standards

The problems that can arise when standardization of medical devices is not used to enhance safety were exemplified

by the Ramstein Air Show Disaster of August 28, 1988. German hypodermic syringes and American connectors proved incompatible, thereby hindering rescue attempts and contributing to injury and death.^{16,17} A coordinated standardization effort resulted in the design of universal intravascular connections. After the Ramstein Air Show Disaster, International Organization for Standardization (ISO) Technical Committee 84, Devices for Administration of Medicinal Products and Intravascular Catheters, undertook standardization of intravenous tubing and published the International Standard ISO 10555-1 in 1995.¹⁸

The importance of international standards is also underscored by the fact that 82% of U.S. exports, by products value, must comply with the relevant International

Table 1. United States Participation in National and International Voluntary Consensus Standards Development for Small-bore Connectors

AAMI	Association for the Advancement of Medical Instrumentation*		
ANSI	American National Standards Institute†		
IEC	International Electrotechnical Commission‡ IEC/TC62/SC62D: Electromedical equipment		
ISO	International Organization for Standardization§ ISO/TC210—Quality management and corresponding general aspects for medical devices		
SDO	Standards Development Organization		
Device Type	ANSI-Approved SDO Holding U.S. Technical Advisory Group	U.S. Technical Advisory Group	International Technical Committee/s (TCs)
Small-bore connectors	AAMI	U.S. Technical Advisory Group to ISO/TC210-IEC 62D	ISO/TC210 IEC/TC62/SC62D

This table lists alphabetically the Standards Development Organizations which define U.S. involvement in the development of International Standards for small-bore connectors. Over 80% of U.S. exports must comply with International Standards.

* Web site at <http://www.aami.org>. Accessed July 19, 2012. † Web site at <http://www.ansi.org>. Accessed July 19, 2012. ‡ Web site at <http://www.iec.ch>. Accessed July 19, 2012. § Web site at <http://www.iso.org>. Accessed July 19, 2012.

Standards.§ Furthermore, governmental agencies adopt or recognize these private sector standards.¹⁹ In 2000, The World Trade Organization's Committee on Technical Barriers to Trade set forth principles to govern International Standards development.²⁰ The World Trade Organization's *Code of Good Practice for the Preparation, Adoption and Application of Standards*, also known as the *World Trade Organization Code of Good Practice*, states that national standardizing bodies should use international standards, or relevant parts of them as the basis for any standards they develop.¶ Although international variations such as power supply infrastructure will prevent complete harmonization among participating countries, the aim of standardization within the medical equipment industry is to improve manufacturing efficiency, trade, safety, and performance of devices.

The Standards Development Process

We have previously described the process of international standardization of medical equipment.²¹ Two Geneva-based nongovernmental organizations bridge the public and private sectors to coordinate the development of international standards. The ISO was created in 1947 and the International Electrotechnical Commission (IEC) was founded in 1906. The membership of ISO includes the national standards institutes of 163 countries. Membership in the IEC comprises 82 National Committees of experts. The development of international standards by technical committees

and their working groups is a formal process that proceeds in established stages to assure consensus of the National Member Bodies and National Committees of ISO and IEC, respectively.^{21,22}

In the United States, the private-sector American National Standards Institute, established in 1916, is the U.S. member body to ISO. American private sector standards development organizations, including the Association for the Advancement of Medical Instrumentation, ASTM International, and the Institute of Electrical and Electronics Engineers are recognized by and operate under American National Standards Institute bylaws and procedures.^{23,24} (table 1).

The Redesign of the Luer Family of Small-bore Connectors

Prevention of misconnection between small-bore connectors requires another coordinated effort to redesign a family of small-bore connectors that will be available globally.

The Brussels-based European Committee for Standardization was founded in 1975 and currently has 32 national members from the European Union. The European Committee for Standardization operates in parallel to ISO, and its European members are also members of ISO. In 2000, the European Committee for Standardization recommended that the Luer-slip and Luer-lok connections be restricted to syringes and devices connected to the vascular system.³ Medical device manufacturers and clinicians alike disagreed, citing cost and physician preference to justify their objections.²⁵ In 2006, an Ad Hoc Meeting of "Interested Parties on Medical Device Small Bore Connectors" held at the Association Française de Normalisation, Paris, proposed the establishment of an international Joint Working Group between ISO Technical Committee 210,

§ James A. Thomas, President of ASTM International (formerly American Society for Testing and Materials), address to Technical Committee ASTM F29 on Anesthetic and Respiratory Equipment, April 12, 2012.

¶ Available at: <http://www.standardsinfo.net/info/intrade.html>; see also http://www.wto.org/english/thewto_e/whatis_e/tif_e/agrm4e.htm. Accessed July 19, 2012.

Table 2. International Standards for Small-bore Connectors

International Standard	Title	Status as of September 30, 2012
ISO 80369-1:2010*	Small-bore connectors for liquids and gases in healthcare applications—part 1: General requirements	Published in 2011
IEC/CD 80369-2†	Small bore connectors for liquids and gases in healthcare applications—part 2: Connectors for breathing systems and driving gases applications	2nd Committee Draft balloted 16 March–16 June 2012: approved‡
IEC/CD 80369-3†	Small bore connectors for liquids and gases in healthcare applications—part 3: Connectors for enteral applications	1st Committee Draft balloted 16 March–16 June 2012: approved‡
IEC/CD 80369-4	Small bore connectors for liquids and gases in healthcare applications—part 4: Connectors for urethra and urinary tubing	To be commenced
IEC/CD 80369-5†	Small bore connectors for liquids and gases in healthcare applications—part 5: Connectors for limb cuff inflation applications	2nd Committee Draft balloted 16 March–16 June 2012: approved‡
IEC/CD 80369-6†	Small bore connectors for liquids and gases in healthcare applications—part 6: Connectors for neuraxial applications	2nd Committee Draft balloted 16 March–16 June 2012: approved‡
ISO/CD 80369-7†	Small bore connectors for liquids and gases in healthcare applications—part 7: Connectors with 6% (Luer) taper for intravascular or hypodermic applications	1st Committee Draft balloted 16 March–16 June 2012: approved‡

* Information available at: http://www.iso.org/iso/home/search.htm?qt=ISO+80369&sort_by=rel&type=simple&published=on. Accessed July 18, 2012. † Information available at: http://www.iso.org/iso/home/store/catalogue_tc/catalogue_tc_browse.htm?commid=54892&development=on. Accessed July 18, 2012. ‡ Earliest possible publication of International Standard, according to ISO/IEC balloting procedures,²² will be 2013. IEC = International Electrotechnical Commission; ISO = International Organization for Standardization.

IEC Technical Committee 62, and the European Committee for Standardization, Committee Technical Board Task Force 123 for the development of standards for small-bore connectors for liquids and gases used in healthcare applications.[#] The ISO-IEC Joint Working Group established has proceeded with the development of a new set of International Standards for small-bore connectors designed for specific health care applications: (1) liquids and gases; (2) breathing systems and driving gases; (3) enteral applications; (4) urethral and urinary tubing; (5) limb cuff inflation; (6) neuraxial; and (7) intravascular or hypodermic (syringe) applications (table 2). The familiar Luer 6% taper male (slip), and the Luer-locking mechanism will be reserved for intravascular and hypodermic (syringe) applications as ISO 80369-7. Neuraxial connections will require a unique small-bore connector system that will not connect

with the Luer intravenous system. The need for coordination of design specifications in the specialized parts of the ISO-IEC 80639 series of standards is recognized.**

Legislative and Regulatory Developments

In recognition of potential harm to patients, the prevention of misconnection among small-bore connections has also been given a high priority by regulatory bodies, worldwide. State of California Assembly Bill 818 (AB 818, Hernandez, Chapter 476, Statutes of 2009) prohibits the use of intravenous, neuraxial, and enteral feeding connection devices that fit into connection ports other than for their intended use.²⁶ Assembly Bill 818 specifies implementation for neuraxial connectors by January 1, 2014, with implementation for intravenous and enteral connections by January 1, 2013. In addition, Assembly Bill 818 requires that the California Advanced Medical Technology Association submit an annual report on the progress of the development of both the relevant International Standards and measures to prevent adverse effects during the introduction of the new devices into clinical practice. The projected publication dates for the relevant International Standards (table 2) do not comply with the timelines specified in this legislation, and in February of 2012, California Assembly Bill AB-1867, *An Act*

[#] Recommendations from the Ad Hoc Meeting of Interested Parties on Medical Device Small Bore Connectors. 27 April 06, Saint-Denis, France, AFNOR. ISO/TC210/N291/April 2006. Available at: http://www.aami.org/Applications/CommitteeCentral-app/Documents/SBC_PA.pdf. Accessed July 19, 2012.

** International Organization for Standardization, ISO/TC210, Quality Management and Corresponding General Aspects for Medical Devices: Resolutions of the Fifteenth Meeting, October 21, 2011, Alexandria, VA, N415, Resolution 147 (Alexandria-6).

to Amend Section 1279.7 of the Health and Safety Code was introduced to delay implementation of the prohibitions for epidural, intravenous, and enteral connectors until January 1, 2016.²⁷ On August 27, 2012, it was signed into law and filed with California's Secretary of State.²⁷

The Australian Commission on Safety and Quality in Health Care, in August 2010, adopted National Recommendations for User Applied Labelling of Injectable Medicines, Fluids and Lines.^{††} These recommendations are being implemented progressively at the Australian state level, having been endorsed by Australian Government Health Ministers and various medical colleges including the Australian and New Zealand College of Anaesthetists. They require the use of target-site-specific identification labels for medication containers and lines, either alone or in combination with color coding according to drug class per Australian Standard/New Zealand Standard 4375: 1996: User-applied labels on syringes containing drugs used during anaesthesia (now incorporated into ISO 26825: 2008). Although this interim measure does not provide a mechanical impediment to incorrect line connections, it may enhance both drug and target-site identification and thereby decrease the risk of misconnections.

The United Kingdom Department of Health, in 2002, urged manufacturers to develop a new non-Luer connector to prevent intrathecal spinal injection errors.²⁸ The timeline established for United Kingdom implementation is more stringent than that of the State of California. A safety alert, to be implemented April 2012 (unchanged at the time of writing this article) requires all hospitals in England and Wales to ensure that non-Luer connectors that cannot connect with intravenous equipment be used for all neuraxial applications.

Small-bore Connector Research and Development: Cautions and Considerations

At least 12 companies are developing non-Luer connector proprietary designs for neuraxial small-bore connectors. Many have not undergone clinical testing. Indeed, clinical testing of many medical devices is not required. In the United States new drugs require a complex Food and Drug Administration evaluation process including analysis of data from clinical trials.¹⁹ Medical devices are not pharmaceuticals and in many jurisdictions including the United States may be brought to market without independent evaluation in patients. The 2011 Position Statement on the Introduction of New Neuraxial Connectors into the United Kingdom

National Health Service²⁸ expressed a high degree of concern for the potential risk to patients from the introduction of new spinal needles and connectors without published independent evaluation in the clinical setting. Representatives of the Associations of Anaesthetists of Great Britain and Ireland, Obstetric Anaesthetists United Kingdom, Regional Anaesthesia United Kingdom, the Paediatric Anaesthetists of Great Britain and Ireland, the Royal College of Anaesthetists, and the Royal College of Anaesthetists Patient Liaison Group all supported this position.

Two evaluations of novel proprietary non-Luer neuraxial connectors highlight the problem. Cook *et al.*²⁹ in evaluating two new non-Luer connectors for neuraxial devices reported that crossconnectivity with Luer devices was still a possibility. In a prospective, simulated use, randomized, industry-funded study evaluating a proprietary non-Luer safety system, Onia *et al.*³⁰ concluded that a proprietary non-Luer safety system was acceptable. However, the authors report that only two thirds of clinician evaluators agreed "the safety system would prevent or reduce the risk of misconnections between a safety syringe filled with medication intended for spinal injection and an intravenous Luer device."³⁰

Manufacturers should seek guidance from the ISO standardization process to avoid development of multiple new devices in advance of the coordinated ISO redesign of the Luer system. This course will minimize confusion and increased risk during the period of transition, thus avoiding a recurrence of the incompatibilities witnessed at Ramstein.

Recommendations to Clinicians

The development of a global redesign of the family of small-bore connectors is a lengthy process, requiring consultation and consensus building across the globe. The design of each unique small-bore connector represents a compromise between engineering, manufacturing, safety, and usability factors. Development of the family of unique small-bore connectors includes the verification and validation of any proposed unique non-Luer device and a risk-assessment "to document...potential mishaps and their mitigations since the complexity of the new situation might invite different types of mechanical or human errors."^{‡‡} As clinicians await the development of a family of unique small-bore connectors, anesthesiologists need to remain vigilant in daily practice for misconnection among the Luer small-bore connectors. Familiarity with published guidelines will reduce the risk of Luer misconnection.⁷⁻¹³ In addition, review of the previously noted Australian National Recommendations for User Applied Labelling of Injectable Medicines, Fluids and Lines may be useful.

The importance of a coordinated effort to redesign the family of unique small-bore connectors is supported by the State of California's legislative decision to await publication of the International Standards. This stance contrasts with the position of United Kingdom to introduce new

†† Available at: <http://www.safetyandquality.gov.au/wp-content/uploads/2012/03/Labeling-Recommendations-2nd-edition-February-2012.pdf>. Accessed July 19, 2012.

‡‡ International Organization for Standardization. Technical Committee 121. Anaesthetic and Respiratory Equipment. Resolutions, 39th Plenary Meeting, 14 and 18 June 2010, ISO/TC121/N938. Available upon request from the Secretariat at: dmlamed@isotc121.org.

and incompletely evaluated neuraxial connectors into clinical practice before the development of unique small-bore connectors and publication of their relevant ISO Standards (table 2).

In a 2007 editorial Bell commented that the implementation of the application-specific small-bore connector system will have a major impact on the practice of anesthesia, “as there will be an obligation not only to implement changes in patient care, but also to embrace a raft of broader professional responsibilities including risk assessment of all areas of practice...”²⁵ Dialogue among clinicians, professional associations, and manufacturers will be fundamental to its success.

References

- Hermann W Luer (of Paris France, Assignor to William Theodore Georgen of New York, NY): Syringe. U.S. Patent 583,382, Application filed December 11, 1896. Washington, D.C., U.S. Patent Office, May 25, 1897
- Dickinson FS: Hypodermic Syringe. U.S. Patent 1,742,497, Application filed Jan. 15, 1925. Washington, D.C., U.S. Patent and Trademark Office. Jan. 7, 1930
- CEN Forum Task Group “Luer Fittings”: Luer connectors – a Report to CEN chef [CEN Health Care Forum] from the CEN Forum Task Group “Luer Fittings”. CEN Report CR 13825. Brussels, CEN, 2000
- International Organization for Standardization (ISO): Conical fittings with a 6% (Luer) taper for syringes, needles and certain other medical equipment. ISO 594-1:1986. Geneva, ISO, 1986
- Vockley M: Dangerous connections: Healthcare community tackles tubing risks. *Biomed Instrum Technol* 2011; 45:426–8, 430–2, 434
- Harris G: U.S. inaction lets look-alike tubes kill patients. *New York Times*, Aug. 21, 2010, A1
- Block M, Horn RJ, Schlesinger MD: Reducing risk of epidural-intravenous misconnections. *APSF Newsletter* 2012; 26:63–5
- ECRI Institute: Top 10 Health Technology Hazards for 2011. *Health Devices* 2010; 39:386–98
- Simmons D, Symes L, Guenter P, Graves K: Tubing misconnections: Normalization of deviance. *Nutr Clin Pract* 2011; 26:286–93
- Noble DJ, Donaldson LJ: The quest to eliminate intrathecal vincristine errors: A 40-year journey. *Qual Saf Health Care* 2010; 19:323–6
- Nicholson Roberts TC, Swart M: Enteral drugs given through a central venous catheter. *Anaesthesia* 2007; 62:624–6
- Joint Commission: Tubing misconnections—a persistent and potentially deadly occurrence. *Joint Commission Sentinel Event Alert* 2006
- Simmons D, Phillips MS, Grissinger M, Becker SC; USP Safe Medication Use Expert Committee: Error-avoidance recommendations for tubing misconnections when using Luer-tip connectors: A statement by the USP Safe Medication Use Expert Committee. *Jt Comm J Qual Patient Saf* 2008; 34:293–6, 245
- Noble DJ, Pronovost PJ: Underreporting of patient safety incidents reduces health care’s ability to quantify and accurately measure harm reduction. *J Patient Saf* 2010; 6:247–50
- U.S. Dept. of Health and Human Services: Office of Inspector General: Adverse Incidents in Hospitals: National Incidence Among Medicare Beneficiaries. Report no. OEI-0609-00090. Washington, DC, U.S. Dept. of Health and Human Services. 2012, p 16
- Dick W: Die Katastrophe von Ramstein: Das Trauerspiel danach. *Notfallmedizin* 1989; 15:8–10
- Seletz JM: Flugtag-88 (Ramstein Air Show Disaster): An Army response to a MASCAL. *Mil Med* 1990; 155:152–5
- International Organization for Standardization (ISO): ISO 10555-1:1995 (and amendments 1999, 2004): Sterile, Single-Use Intravascular Catheters –Part 1: General Requirements. Geneva, ISO, 1995
- Institute of Medicine of the National Academies. Board on Population Health and Public Health Practice. Committee on the Public Health Effectiveness of the FDA 510(k) Clearance Process: Medical Devices and the Public’s Health. The FDA 510(k) Clearance Process at 35 Years. Washington, DC, National Academies Press, 2011
- Weiss J. International trade and standards. *ASTM Standardization News*. 2011;39:28–31
- Hedley-Whyte J, Milamed DR: Equipment standards: History, litigation, and advice. *Ann Surg* 1999; 230:120–7
- International Organization for Standardization, International Electrotechnical Commission: ISO/IEC Directives, Part 1. Procedures for the Technical Work. 9th edition. Geneva, ISO, IEC, 2012
- American National Standards Institute: ANSI Essential Requirements: Due process requirements for American National Standards. New York, ANSI, 2012
- American National Standards Institute: ANSI Procedures for U.S. Participation in the International Standards Activities of ISO. New York, ANSI, 2012
- Bell D: Recurrent wrong-route drug error — a professional shame. *Anaesthesia* 2007; 62:541–5
- State of California: Assembly Bill No. 818. Chapter 476. An Act to Amend Section 1279.7 of the Health and Safety Code, Relating to Health Facilities. [Approved by Governor October 11, 2009. Filed with Secretary of State October 11, 2009.]
- State of California: Assembly Bill AB-1867 Health Facilities. Equipment Standards (201–2012). An Act to Amend Section 1279.9 of the Health and Safety Code, Relating to Health Facilities. Amended in Assembly March 29, 2012; Signed into law, August 27, 2012
- Association of Anaesthetists of Great Britain and Ireland, Royal College of Anaesthetists, Obstetric Anaesthetists’ Association, Regional Anaesthesia UK, Association of Paediatric Anaesthetists of Great Britain and Ireland, Royal College of Anaesthetists Patient Liaison Group: The Introduction of New Neuroaxial Connectors into the NHS. Position statement. Updated October 25, 2011
- Cook TM, Payne S, Skryabina E, Hurford D, Clow E, Georgiou A: A simulation-based evaluation of two proposed alternatives to Luer devices for use in neuraxial anaesthesia. *Anaesthesia* 2010; 65:1069–79
- Onia R, Wu Y, Parvu V, Eshun-Wilson I, Kassler-Taub K: Simulated evaluation of a non-Luer safety connector system for use in neuraxial procedures. *Br J Anaesth* 2012; 108:134–9